

# The FlightLine

Next Meeting February 18th ! Gotta Be There Or Else!

February, 2006

## **THE FLIGHTLINE**

OFFICIAL NEWSLETTER  
OF EAA CHAPTER 40  
VAN NUYS / SAN  
FERNANDO VALLEY,

DEDICATED TO THE HOBBY  
& SCIENCE OF AIRCRAFT  
BUILDING, RESTORATION,  
YOUTH OUTREACH  
THROUGH AVIATION, AND  
FOSTERING THE GROWTH  
OF PRIVATE AVIATION AND  
AIR SPORTS.

**CHAPTER MEETINGS** ARE  
OPEN TO ALL, AND ARE  
HELD AT 9AM ON THE 3RD  
SATURDAY OF EACH  
MONTH, AT ROCKY'S RES-  
TAURANT AT WHITEMAN  
AIRPORT

CALL 818-705-2744 FOR  
MORE INFO.

[www.eaa40.org](http://www.eaa40.org)



## **Second Floor... Fuselages, Tinnerman Nuts, Cotter pins!**

Chapter 40 is going vertical! Well, maybe not with Tom Cruise in an F-14, but we're movin' on up in our own way. The hangar we rent is blessed with a high ceiling and a strong frame. High and strong enough for a mezzanine, to be exact.

Thanks to the efforts of hangar manager Ferd Kuhn, the floor space of the hangar is now 100% occupied with paying tenants. It has dawned on your fearless chapter leadership that several other hangars at Whiteman have been outfitted with a second floor storage mezzanine. This would add another 50 to 75% usable space to our hangar, which means two important things.

First, it provides more space for homebuilders to safely store their projects, parts, supplies etc. Second, the hangar could become a greater source of income for the chapter, buying gas for Young Eagles flights, sponsoring more events, and the promotion of local sport aviation. Moreover, we'll be able to have the first floor for active projects and flying aircraft, and the mezzanine for storage of projects and parts.

To this end, we now have a proposition for you: If you have any building materials that would be used for the construction of this mezzanine, we can offer you a significant tax advantage for donating these materials. We'll need steel framework, studs and rails, plywood, electrical supplies, lights, fasteners, etc. Please contact any chapter officer for more details.

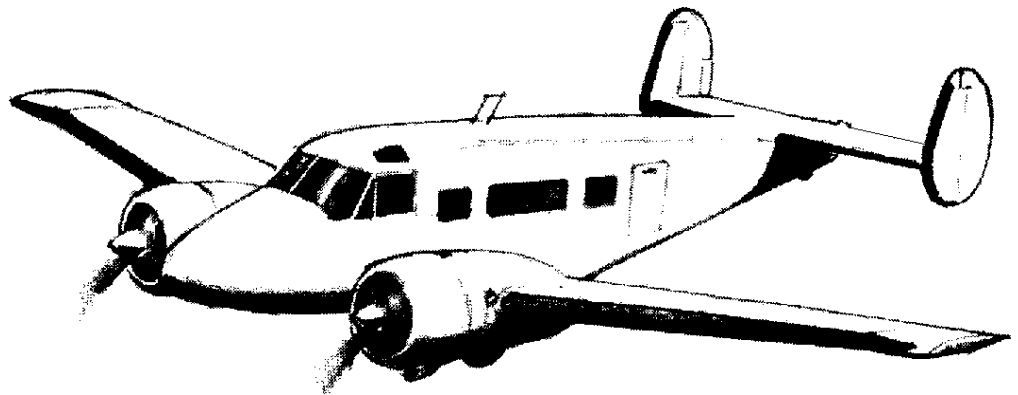

**EAA Chapter 40 Hotline**

**818-725-4AIR**

*President - Charles Ducat Vice President - Dave Kolstad*

*Treasurer - Ferd Kuhn Secretary - Tom Hastings*

*Young Eagles Co-ordinator - Alycia Herman Newsletter - Bill Berle*

## Farewell John Frymyer

Some of you have heard the news by now that Whiteman Airport Manager John Frymyer will be leaving Whiteman. This has been verified and can now be announced.

John has accepted an offer to become the manager of Chino Airport on behalf of San Bernardino County. This will be a reportedly more lucrative position as well as a far shorter daily commute for John. Some people at Whiteman appreciated John's efforts and some people were unhappy with him. This

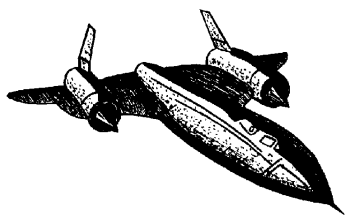

proves the old adage that you can't make everyone happy.

Whether you were a supporter of his or not, the fact remains that Chapter 40 received better treatment and enjoyed a much more favorable status on the airport during John's tenure than under any previous administration. Chapter 40 wishes John Frymyer well and sends a sincere thanks to him for his efforts on behalf of our activities.

## Dues are Still Due

Anyone who has not paid their annual \$20 dues must bring cash or check to the next meeting, February 18<sup>th</sup>.

If you are not paid up at that time, we will be taking the non-renewed memberships off the roster and you will fall into the great abyss of the forgotten. That's a terrible place to be, not to mention the little monsters down in the bottom of that abyss that will start eating you piece by piece.

Please, for your own safety, make sure you have paid your annual dues on or before February 18<sup>th</sup> and be saved from the forgotten pit of little hungry monsters.

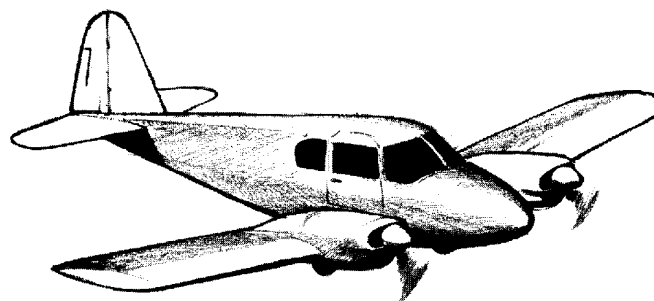

## *Rockin' to the Beat of Aviation!*

Step aside Dick Clark, aviation is what's rockin' and rollin' this summer at the Van Nuys Airport Rockin' Air Fest 2006! Not to be confused with any old air fair, this is the 2006 version of the world famous Van Nuys Air Fair.

This year's event will take place on Sunday June 11<sup>th</sup>, from 9AM to 5PM. The people who predict these things expect about 5000 visitors. This year, the theme is a salute to the **Commemorative Air Force**. The CAF used to also be known as the CAF, but now it's the CAF because the first C was offensive to the political correctness police and too many candy-a\*\*es complained, so now they had to go back and change the official name from C to shining C. So make sure you CYA and don't call it the CAF or CQ might call the CIA and then nobody would ever C you again.

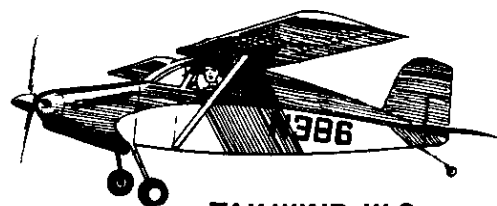

**TAILWIND W-8**

As far as the Air Fair itself, it's up to us to discuss exactly what we want to do for a booth. We probably won't be flipping burgers or pouring sodas this time around. This event will not be a big chapter money-maker, we'll be there simply promoting sport aviation. Please come up with ideas, suggestions and discussion items at the next meeting so we can figure out what the best use of our resources is. Again, be ready to discuss this at the upcoming meeting February 18<sup>th</sup>.

## Next Young Eagles February 25<sup>th</sup>

Chapter 40 members have made the decision that we should be doing the Young Eagles event monthly, and we have committed to do so. Because of this, we now have a need for more creative and effective ways to get the numbers of participants to make it worthwhile. We need everyone's help and creative ideas, such as school visits and school presentations, electronic mail advertising, web advertising, flyers, painting the side of MTA buses, 30 second commercials during the Super Bowl, etc. We want your creativity and your ideas on how to make the creative ideas into reality. Be ready to discuss this at the next meeting too.

## March AFB Event

We received this from the folks at March AFB...

Dear EAA Chapter President;

On April 29<sup>th</sup> and 30<sup>th</sup>, 2006, March Air Reserve Base has a commitment to present an Extravaganza, an event we hope will be our biggest and best air show ever – AirFest 2006. We are expecting about 500,000 attendees over that weekend. They will come to enjoy the excitement of the USAF Thunderbirds and many other military and civilian air acts.

## OK,Girls, He's Legal!

Chapter 40's own poster boy for aviation, **Jesse Galeas**, turned 18 on Wednesday the 15<sup>th</sup>. The chapter would like to officially wish Jesse a happy birthday. We have rented Jesse a full time security guard to keep women of all ages from going after him now that he is legally an adult.

In related news, Jesse will now be able to work legally in aviation to support his training. The future is very bright for Jesse, partly because of the efforts of Chapter 40, the 99's and the Aviation Explorers. But Jesse has also put in the time, effort and hard work as well, and he deserves our respect and thanks for taking the opportunity that was offered to him and making the most out of it. Jesse has exceeded all of our hopes and expectations and is earning all of the goodwill and opportunities that are coming his way. Bravo, Jesse!

If anyone is aware of an aviation-related job opportunity for a motivated, high quality, career minded young man, please contact any chapter officer and we will put Jesse in touch with you.



## Yet Another Aviation Youth Success Story !

In January, a young lady named **Erin Thorpe** passed her private pilot tests with flying colors. Erin was another participant in Ruth Logan's Aviation Explorer Scouts program. Chapter 40 enthusiastically supports Ruth in her fantastic efforts bringing aviation and kids together.

## B-17 Moving Forward Full Steam

The B-17 tour visit on the weekend of April 15<sup>th</sup> is moving forward. Chapter 40 members **Ann Marie Radel**, Elliot Sanders and Charlie Ducat will be in charge, with help and assistance from each of the chapter members. Please keep this weekend open, because the B-17 event is the only significant source of income that Chapter 40 has at this point. We will be strongly requesting the participation of each of you to make this a reality.

## Donations Now and Donations Later

Chapter 40's application for a 501 (c) 3 non-profit status is still in the works, but has stalled temporarily. We're working hard with our volunteer lawyer and accountant to untangle the problems, but there will not be an immediate resolution.

In the meantime, we have a working, successful agreement with the Traveling Space Museum to process donations through their organization. What does this mean? It means that you can NOW donate money, parts, projects, books, tools, cars, etc. to Chapter 40. Your donation will also provide a small but useful benefit to TSM, whose mission is also aerospace education and outreach.

Your donations will help Chapter 40 keep our existing rented hangar and eventually build a permanent facility, support our Young Eagles program, and promote sport aviation, homebuilding, antique restoration and aviation education.

---

## Future of Whiteman Air Fair

Now that John Frymyer is leaving Whiteman, the question is raised as to how Chapter 40 wants to proceed with an **annual airport event** at our home field. The Optimist Club is no longer involved with events at Whiteman, following a series of fizzled events under their leadership.

However, two or three other non-profit entities have always existed in our area that we can count on. The 99's have a strong track record at air fairs, the Traveling Space Museum has strong connections and inroads in local government, the Whiteman Airport Association has become strong and well respected, and the Civil Air Patrol has been based at Whiteman for many years as well. Between ourselves and these other groups, who all have a specific interest in promoting aviation at this airport, and the support of airport management, it appears that a partnership can be formed to promote and produce a Whiteman Air Fair.

The opportunity exists to create a major local event that is under our leadership instead of someone else's, and puts our interests first. Chapter 40 has paid its dues as a second-level player at local airshows, and the opportunity is here now for us to become the leader. Folks, THIS is the path toward strengthening our position politically and economically at Whiteman. Please be prepared to discuss this at the next meeting.

---

## Best Wishes Department

Mike Langdon has returned from the hospital and is recovering nicely from some minor heart problems. The doctors may suggest a pacemaker, although Mike already receives regular jolts from the 300 Amp welding machines he operates... Chapter 40 has sent an official letter to the doctors making sure they install the biggest pacemaker they have, since everyone knows Mike Langdon has the biggest heart of anyone we've ever met. Get well soon, Mike, we all love you.

Chapter 40's Engineer Emeritus Vance Jacqua is also recovering well from surgery. Please join all of our members in wishing Vance a complete and speedy return to his old self. Vance's knowledge and brain-power is one of American aerospace's greatest treasures, and Vance's willingness to share it with others is one of Chapter 40's greatest treasures.

Also, please join us in sending our best wishes to Kathy Clement for a quick recovery from a spell of poor health. Kathy and Paul are nearing completion of a Zenair



## The Pampered Chef ?

That's right! If you love to cook, if you're interested in top notch equipment for your home kitchen, and if you love great food... you're invited.

Chapter 40's Young eagles coordinator Alycia Herman is hosting a Pampered Chef event this Friday, February 17<sup>th</sup> at 7:30 PM in our home at 10125 DeSoto, unit #7, in Chatsworth. The event will feature cooking demonstrations, great kitchen gadgets and products (no pressure), great people and a lot of fun.

Speaking as a lucky previous beneficiary of food cooked with these products, please accept the assurance of your newsletter editor that Pampered Chef cookware makes food more delicious. Please contact Alycia Herman at 818-701-6801 for more info.

## Aviation Gifts Galore!

Chapter 40 member Ruth Logan has started a business to offer unique and delightful Aviation Gifts, pilot supplies, books and novelties.

Her business will offer inspiring and educational aviation related gifts for children, as well as pilots and aviation enthusiasts of all ages.

Please spend a few minutes looking through her website, [www.aviationgiftsbyruth.com](http://www.aviationgiftsbyruth.com) to have a look. Chapter 40 strongly supports Ruth's new venture, not only because she has contributed so much of her time and effort, but also because a focus of the business is gifts and educational materials fostering aviation for children.

96  MOYES Planeur 1981

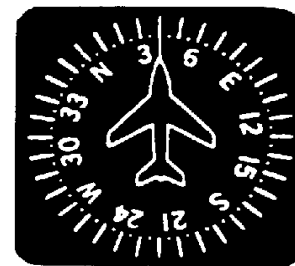
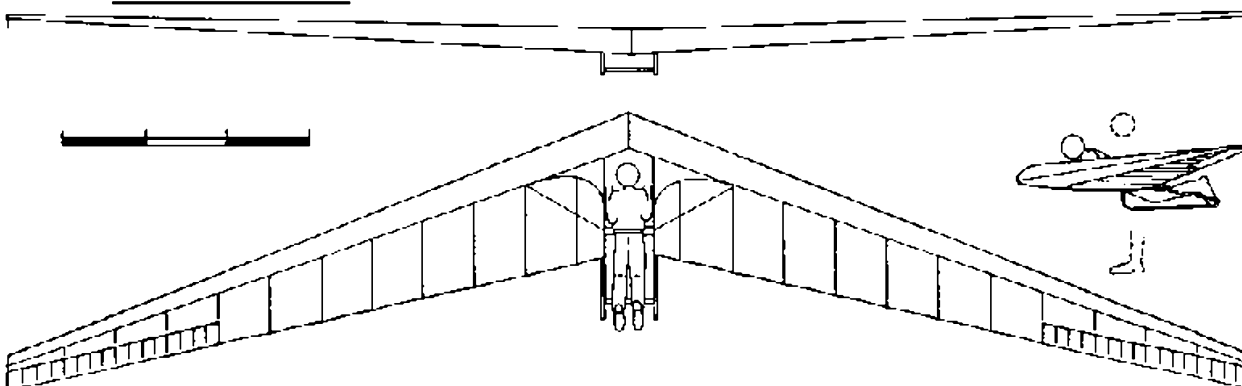

EAA Chapter 40  
c/o Dave Kolstad  
8860 Shoshone Ave  
Northridge, CA 91325

**Newsletter Editor**

Bill Berle [victorbravo@sbcglobal.net](mailto:victorbravo@sbcglobal.net) 818-701-6801